

2008



SouthEast Asia Regional Conference

4-6 December 2008

Kuala Lumpur

Globalization, Innovation, and Leadership

Organizer: Hong Kong Institute of Business Studies



Conference Venue: Renaissance Kuala Lumpur Hotel

Notes to Participants

1. Venues and Time

<u>Date & Time</u>	<u>Event</u>	<u>Venue</u>
3 December 2008 Wednesday	16:00 – 18:00 Early Registration	G/F, Convention Center
4 December 2008 Thursday	09:00 – 09:30 Registration	Function Rooms 5-6
	09:30 – 11:15 Opening Plenary	G/F, Convention Center
	11:30 – 13:00 Concurrent Sessions 1	Function Rooms 4-6
	13:00 – 14:30 Lunch	Convention Center, G/F TEMPTationS, G/F, East Wing
	14:30 – 16:00 Concurrent Sessions 2	Function Rooms 4-6
	16:15 – 18:15 Concurrent Sessions 3	Convention Center, G/F
	18:45 – 21:00 Conference Dinner	Poolside, 4/F
5 December 2008 Friday	09:00 – 11:00 Concurrent Sessions 4	Function Rooms 4-6
	11:15 – 12:45 Concurrent Sessions 5	Convention Center, G/F
	12:45 – 14:00 Lunch	Vogue Café, G/F, West Wing
	14:00 – 16:00 Concurrent Sessions 6	Function Rooms 4-6
	16:15 – 18:15 Concurrent Sessions 7	Convention Center, G/F
6 December 2008 Saturday	09:00 – 10:30 Concurrent Sessions 8	Function Rooms 5-6
	10:45 – 12:45 Concurrent Sessions 9	Convention Center, G/F

Location:

Renaissance Kuala Lumpur Hotel
Corner of Jalan Sultan Ismail & Jalan Ampang
50450, Kuala Lumpur
Malaysia

Function Rooms 4-6, Ground Floor, Convention Center

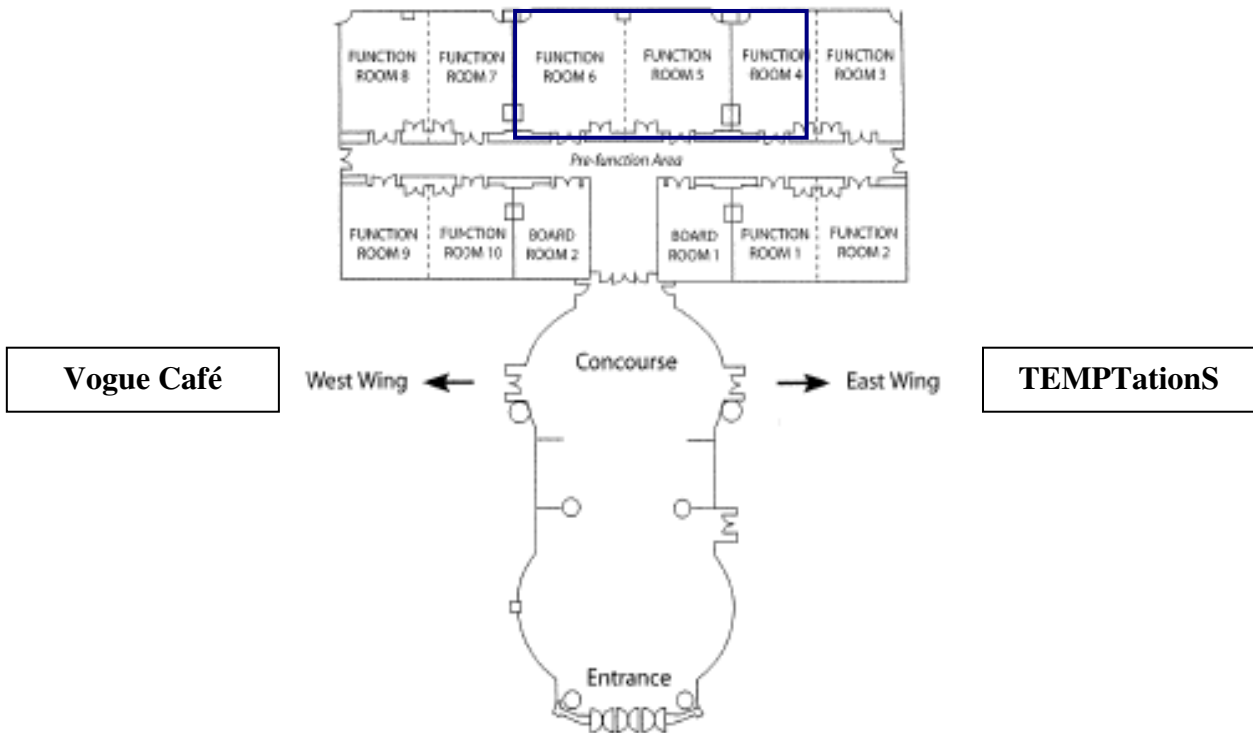

2. Presentation Time

There are tentatively 25 concurrent sessions and each session lasts for about 90 minutes or 120 minutes. The total session time should be allocated equally among speakers, with approximately 20 minutes for each paper presentation, depending on the number of papers being presented in the session. The Chair should decide whether “Question & Answer” (Q & A) is conducted when the session ends (preferred) or after each speaker has finished. Each session will have 30 minutes for Q & A.

3. Presentation Equipments

The following presentation equipments will be installed in each meeting room:

- ✧ Overhead projector (only 1 overhead project is available for the conference use, please reserve it in advance, first come first serve.)
- ✧ Flipchart
- ✧ Whiteboard
- ✧ Microphones
- ✧ PC (Window XP) with LCD projector*

* Please save your powerpoint file to **Microsoft PowerPoint 2003 version** and give it to the Conference Secretariat in advance.

4. Conference Bag

The following items will be included in the conference bag:

- ✧ CD Conference Proceedings
- ✧ Conference Programme
- ✧ Lingnan University Leaflet
- ✧ Receipt of the conference registration fee *
- ✧ Name tag #
- ✧ Presenters' information (only for Chairperson)

* *A list of new/renewed members will be sent to the AIB Head Office after the Conference. AIB Head Office will inform you of the membership status via e-mail message.*

Please wear your name tag to attend the conference activities for identification, particularly during meal time.

5. Hotel Check-in/Check-out Time

The official check-in time is 14:00 and check-out time is 12:00 for Renaissance Kuala Lumpur Hotel. Please contact the Hotel for early arrival or late departure (subject to availability).

6. Transportation between Kuala Lumpur International Airport (KLIA) and Renaissance Kuala Lumpur Hotel

Hotel Limousine: 75 km, about 45 minutes drive

Aiprot Pick Up/ Airport Send Off : RM200 nett per car
After midnight (12mn – 6 am) : 50% surcharge applies

Please contact Renaissance Kuala Lumpur Hotel directly for the limousine services.

Note: all limousine bookings require credit card guarantee. Any cancellations without 24 hours prior notice or no show will be chargeable in full.

Taxi: about RM120 for traveling between KLIA and KL city center.

KLIA Ekspres: It costs about RM35/journey for traveling between KLIA to KL Sentral Station (about 30 minutes) by KLIA Ekspres. At KL Sentral Station, either take Putra Light Rail Transit "LRT" to station "DangWangi" (costs RM1.6) or KL Monorail to station "Bukit Nanas" (costs RM3.1).



- Kelana Jaya Line**
Between Terminal PUTRA (Gombak) and Kelana Jaya
23 stations over 29 km, operated by *RapidKL Rail*
- Ampang Line (Yellow and Green lines)**
Between Sentul Timur and Sri Petaling
18 stations over 15 km, operated by *RapidKL Rail*
Between Sentul Timur and Ampang
18 stations over 16 km, operated by *RapidKL Rail*
- Sentul-Port Klang Line**
Between Sentul and Port Klang
22 stations over 183 km, operated by *KTM Komuter*
- Rawang-Seremban Line**
Between Rawang and Seremban
23 stations over 183 km, operated by *KTM Komuter*
- Rawang-Kuala Kubu Bharu Route**
Between Rawang and Kuala Kubu Bharu
8 stations over 22 km, operated by *KTM Komuter*
- KL Monorail**
Between KL Sentral and Titiwangsa
77 stations over 8.6 km, operated by *KL Monorail*
- KLIA Ekspres**
From KL Sentral to KLIA
Non-stop over 75 km, operated by *ERL*
- KLIA Transit**
Between KL Sentral and KLIA
8 stations over 75 km, operated by *ERL*

Source: Wikipedia Online
(http://en.wikipedia.org/wiki/Public_transport_in_Kuala_Lumpur)

The Role of the Presenter

Abstracted from “Making AOM Sessions Exciting!”, by Jing Zhou (Texas A&M) and Russ Coff (Emory).

Presenter:

The presenter’s job is to “sell the paper” and convince the audience that it is worth reading. This requires emphasis of the contribution rather than a summary of all sections of the paper.

The following are some ideas for how authors can get the audience engaged and excited about the paper. Most practices in the DON’T” column are standard procedure and the suggestions may seem radical. However, the object should be a presentation that covers less but makes a compelling argument that the paper should be read.

	DO NOT	DO
Purpose of Presentation	Present summaries of all sections of the paper	Present enough to tell the audience that the paper is worth a read – tell a good story. Focus on the contribution. Minimize discussion of sections that don’t stress what is new and different
Presentation Format and Timing	Save the punch line as a sort of surprise ending. Plan for 20 minutes in case there is extra time. Use small fonts or too many overheads	Consider starting with the conclusion and then explain why you reached it (e.g. methods/results). Provide a 1-page handout describing your contribution and key points. Plan for 10 minutes – it is easier to elaborate than to cut things out. Use fonts larger than 28 pt and no more than 10 overheads or slides
Audience Interaction	Give a monologue describing your research	Create expectations that you expect active audience participation. Survey/work the audience before the session starts. Look people in the eye and talk to them (not at them). Identify places for audience input and ask questions. Consider using brief exercises or scenarios that draw on the audience’s personal experiences/ knowledge. Offer an interactive data analysis (“mess with the data”) by inviting the audience to make assumptions and suggest relationships to test
Introduction	Focus on why you decided to do the study	Focus on what is interesting and new about what you have learned. Do try to start off with a real world analogy/story
Theory	Present a broad literature review (cites, etc.). Explain every arrow in a complex figure	State the problem, why it is interesting, and what you will add. Explain what is new in this model over past contributions
Methods	Describe the sample measures, and validation of instruments	Provide an overview of why the measures are linked to the theoretical construct. Establish face validity and assure that more rigorous methods were applied
Results	Present any tables with numbers	Present what was significant (+ and – signs). Explain what the data tell you – not tests. People can read the paper to get details
Conclusion	Review each result and summarize what was significant	Answer broadly what we have learned and what needs to be done now. Urge the audience to read the paper for details